

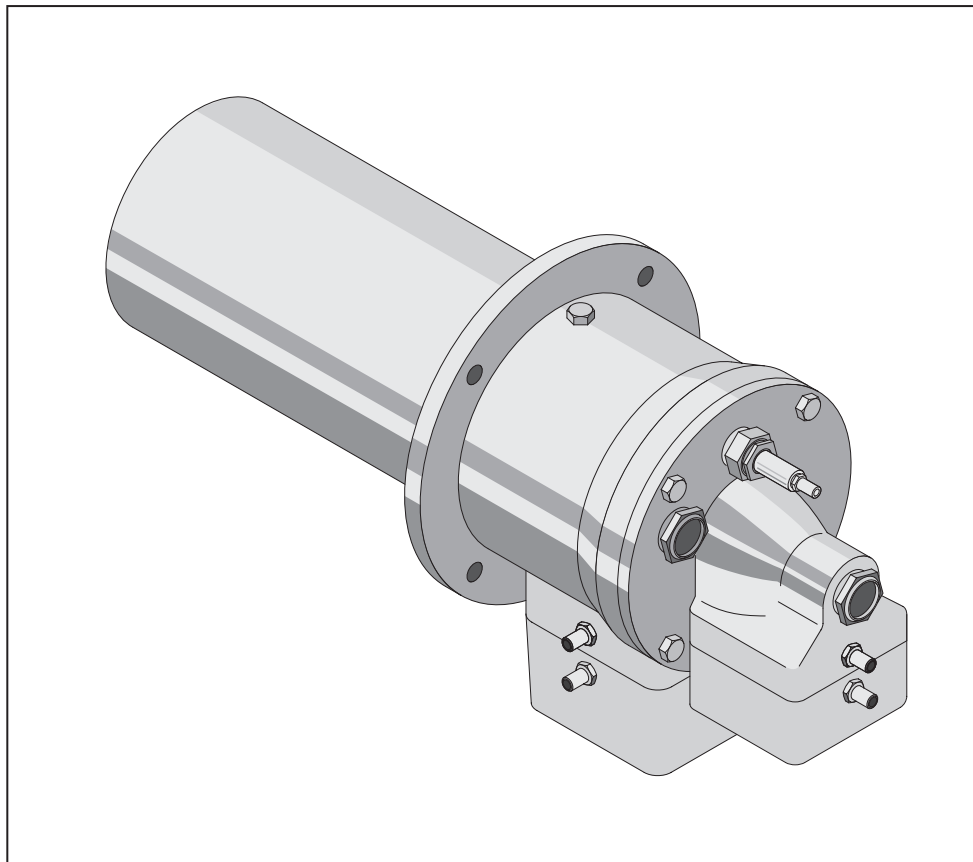

TubeFiring Burners

*ThermThief Series
Version 2*



COPYRIGHT

Copyright 2004 by Eclipse, Inc. All rights reserved worldwide. This publication is protected by federal regulation and shall not be copied, distributed, transmitted, transcribed or translated into any human or computer language, in any form or by any means, to any third parties, without the express written consent of Eclipse, Inc., Rockford, Illinois, U.S.A.

DISCLAIMER NOTICE

We reserve the right to change the construction and/or configuration of our products at any time without being obliged to adjust earlier supplies accordingly.

The material in this manual is believed adequate for the intended use of the product. If the product, or its individual modules or procedures, are used for purposes other than those specified herein, confirmation of their validity and suitability must be obtained. Eclipse, Inc. warrants that the material itself does not infringe any United States patents. No further warranty is expressed or implied.

We have made every effort to make this manual as accurate and complete as possible. Should you find errors or omissions, please bring them to our attention so that we may correct them. In this way we hope to improve our product documentation for the benefit of our customers. Please send your corrections and comments to our Documentation Manager.

LIABILITY AND WARRANTY

It must be understood that Eclipse's liability for its products, whether due to breach of warranty, negligence, strict liability, or otherwise, is limited to the furnishing of such replacement parts and Eclipse, Inc. will not be liable for any other injury, loss, damage or expenses, whether direct or consequential, including but not limited to loss of use, income of or damage to material arising in connection with the sale, installation, use of, inability to use or the repair or replacement of Eclipse's products.

Any operation expressly prohibited in this Guide, any adjustment, or assembly procedures not recommended or authorized in these instructions shall void the warranty.



About this manual

AUDIENCE

This manual has been written for people who are already familiar with all aspects of a nozzle-mix burner and its add-on components, also referred to as "the burner system."

These aspects are:

- design/selection
- use
- maintenance.

TFB DOCUMENTS

Design Guide No. 310

- This document

Data Sheet No. 310-1 through 310-3

- Available for individual TFB models
- Required to complete design calculations in this guide

Installation Guide No. 310

- Used with Data Sheet to complete installation

Price List No. 310

- Used to order burners

RELATED DOCUMENTS

- EFE 825 (Combustion Engineering Guide)
- Eclipse bulletins and Info Guides:
610, 710, 720, 730, 742, 744, 760, 930, I-354.

Purpose

The purpose of this manual is to make sure that the design of a safe, effective and trouble-free combustion system is carried out.

DOCUMENT CONVENTIONS

There are several special symbols in this document. You must know their meaning and importance.

The explanation of these symbols follows below. Please read it thoroughly.



Danger:

Indicates hazards or unsafe practices which WILL result in severe personal injury or even death.

Only qualified and well trained personnel are allowed to carry out these instructions or procedures.

Act with great care and follow the instructions.



Warning:

Indicates hazards or unsafe practices which could result in severe personal injury or damage.

Act with great care and follow the instructions.



Caution:

Indicates hazards or unsafe practices which could result in damage to the machine or minor personal injury, Act carefully.



Note:

Indicates an important part of the text. Read thoroughly.

HOW TO GET HELP

If you need help, contact your local Eclipse Combustion representative.



Table of contents

	About this manual	3
	Table of contents	5
1	Introduction	6
	Product Description	6
2	Safety	7
	Introduction	7
	Safety	7
	Capabilities	7
	Operator Training	8
	Replacement Parts	8
3	System design	9
	Design.	9
	Step 1: Burner selection and tube design	9
	Step 1a: Radiant tube burner application	9
	Sizing example.	12
	Step 1b: Immersion tube burner application	14
	Step 2: Control methodology	18
	Step 3: Ignition System.	20
	Step 4: Flame monitoring system	20
	Step 5: Combustion Air System: Blower and air pressure switch	21
	Step 6: Main gas shut-off valve train	23
	Step 7: Process Temperature Control System	23
	Appendix	25

Introduction

1

PRODUCT DESCRIPTION

The ThermThief is a nozzle-mixing burner designed for tube firing applications with multiple fuel capability. The burner consists of a housing, rear cover, air and fuel inlet blocks, spark rod, flame rod (if selected), gas tube, nozzle and air shroud.

Burner design provides:

- Adjustable air shroud to maintain correct air velocity for different sized tube applications and fuels
- Uniform tube temperatures for extending tube life

Figure 1.1 The ThermThief burners

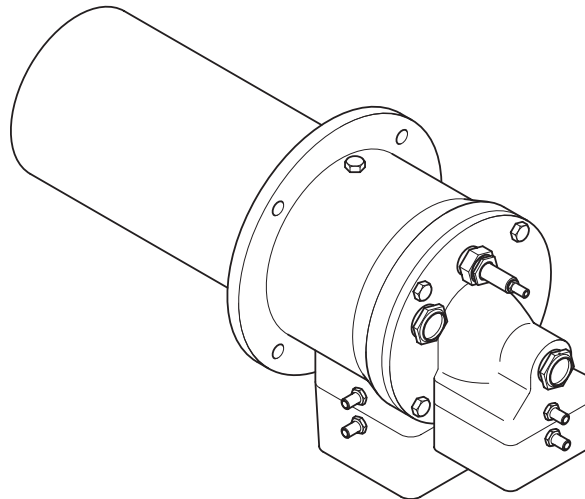

Heat exchanger

The ThermThief can be used with or without an exhaust leg recuperator. An exhaust leg recuperator is a heat exchanger that transfers heat from the exhaust air to the combustion air.

Preheating the combustion air can increase the fuel efficiency by as much as 20%. The ThermThief can handle combustion air temperatures up to 800°F.

The recommended recuperators for the ThermThief are the Eclipse Bayonet (Data 317) and the Bayonet-Ultra (Spec. 318).



2

INTRODUCTION

SAFETY

This section is provided as a guide for the safe operation of the TFB burner system. All involved personnel should read this section carefully before operating this system.



Danger:

The TFB burners, described herein, are designed to mix fuel with air and burn the resulting mixture. All fuel burning devices are capable of producing fires and explosions if improperly applied, installed, adjusted, controlled, or maintained.

Do not bypass any safety feature; fire or explosion could result.

Never try to light a burner if it shows signs of damage or malfunction.



Warning:

The burner might have HOT surfaces. Always wear protective clothing when approaching the burner.



Note:

This manual provides information in the use of these burners for their specific design purpose. Do not deviate from any instructions or application limits described herein without written advice from Eclipse.

Read this entire manual and all related documents before attempting to start this system. If you do not understand any part of the information contained in this manual, contact your local Eclipse representative or Eclipse before continuing.

CAPABILITIES

Only qualified personnel, with good mechanical aptitude and experience on combustion equipment, should adjust, maintain, or troubleshoot any mechanical or electrical part of this system.

OPERATOR TRAINING

The best safety precaution is an alert and trained operator. Train new operators thoroughly and have them demonstrate an adequate understanding of the equipment and its operation. A regular retraining schedule should be administered to ensure operators maintain a high degree of proficiency.

REPLACEMENT PARTS

Order replacement parts from Eclipse Combustion only. All Eclipse Combustion approved, customer supplied valves or switches should carry UL, FM, CSA, CGA, and/or CE approval, where applicable.

System Design

3

DESIGN

Step 1: Burner selection

Step 1a: Radiant tube burner application

Design Structure

Designing a burner system is a straight-forward exercise of combining steps that add up to a reliable and safe system. These steps are:

1. Burner selection and tube design.
2. Control methodology.
3. Ignition System.
4. Flame monitoring system.
5. Combustion Air System: Blower and air pressure switch.
6. Main gas shut-off valve train.
7. Process Temperature Control System.

The design of a combustion system for radiant tubes and immersion tubes is significantly different. For this reason, we have divided the process for burner selection into two separate sections;

- "**Step 1a:** Radiant tube burner application" on page 9
- "**Step 1b:** Immersion tube burner application" on page 14.

All individual burner performance data including dimensions, capacities, operating parameters and emissions information can be found in the following Data Sheets:

- 310-1 Data 30 TFB • 310-2 Data 75 TFB • 310-3 Data 200 TFB

Fuel type

The usable fuel types are:

- natural gas
- propane
- butane.

For other fuels, contact Eclipse Combustion with an accurate breakdown of the fuel contents.

Air type

- ambient
- preheat.

Calculate the required heat release per tube

Given the net heat requirement of the furnace (Btu/hr), divide by the number of radiant tubes to determine the required heat release per tube.

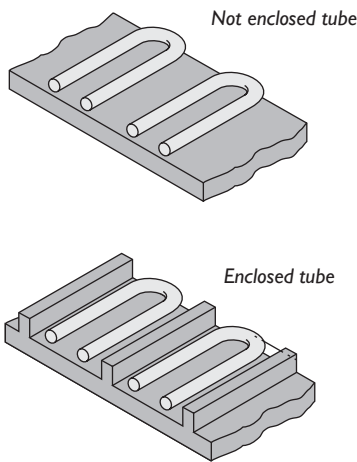
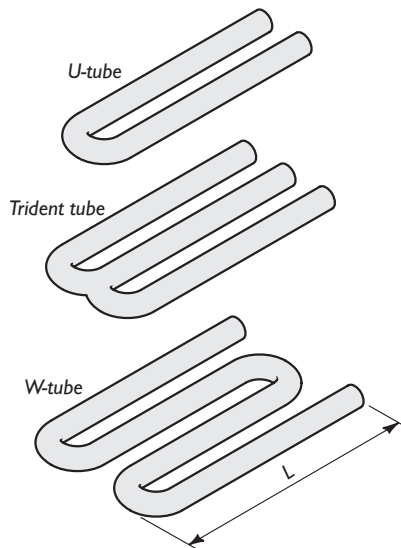

Calculate the tube surface area

The burner radiates its heat to the process through the wall of the tube. To calculate the required burner input you must know the total area of the tube inside the furnace.

To calculate the tube surface area, use this formula:

$$\text{Tube surface area} = OD \times \pi \times n \times L$$

- OD = the outside diameter of the tube in inches.
- $\pi = 3.142$
- n = number of tube legs
 - 2 for a U-tube
 - 3 for a trident tube
 - 4 for a W-tube.
- L = the total length of each leg in inches.

Determine the maximum heat transfer rate

The maximum heat transfer rate is the maximum amount of heat that the tube can radiate to the process per time unit.

The maximum heat transfer rate of a tube depends on the temperature of the chamber and how the tube is mounted inside the furnace. A tube can be enclosed in the structure of the furnace or not enclosed.

An enclosed tube has a lower maximum heat transfer rate than a tube which is free to radiate in all directions.

Table 3.1 Maximum heat transfer rate

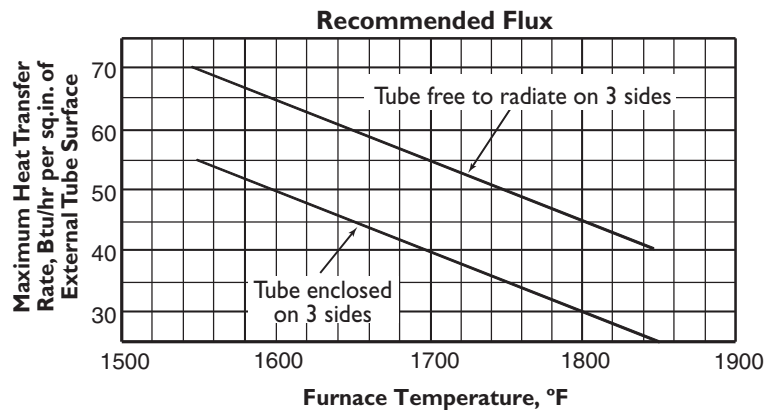

Calculate the maximum heat release

Multiply the previously calculated tube surface area by the maximum heat transfer rate:

$$\text{Maximum heat release} = \text{tube surface area} \times \text{max heat transfer rate}$$

Compare the heat releases

Compare the *required* heat release with the *maximum* heat release.

If the required heat release is greater than the maximum heat release, then the number or the size of the radiant tubes must be increased.



Caution:

Exceeding the maximum heat release will significantly shorten the tube life.

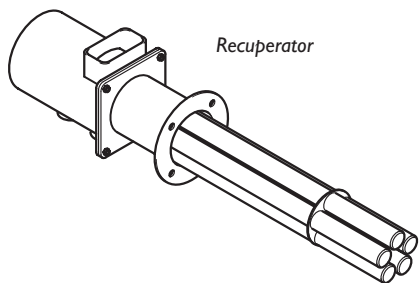

Determine efficiency

Decide whether or not you want to use a recuperator. A recuperator is a heat exchanger which uses heat from the exhaust to pre-heat the combustion air. The effect of a recuperator on the efficiency of the system can be significant, as shown in the table below

Table 3.2 Efficiency

FURNACE CHAMBER TEMPERATURE (°F)	% EFFICIENCY	
	WITHOUT RECUPERATOR (AMBIENT AIR)	WITH RECUPERATOR (PREHEATED AIR)
1000	57	71
1300	51	68
1550	47	65
1650	44	64
1750	41	63
1850	39	62

Calculate the gross burner input

Calculate the gross burner input (Btu/hr) with this formula:

$$\text{Gross burner input} = \frac{\text{Required heat release}}{\text{Efficiency}}$$

Compare the gross burner input

Compare the gross burner input with the maximum tube input. If the gross burner input is greater than the maximum tube input from the table below, then the size of the radiant tube must be increased.

Table 3.3 Maximum tube input

TUBE I.D. (INCHES)	MAXIMUM INPUT (1000's BTU/HR)
4	300
5	600
6	900
8	1500
10	2500
12	3500

Exceeding these inputs may result in burner pulsation or other operational problems.

Sizing example

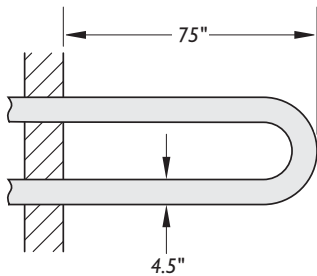

Application parameters

- 4 U-tubes - 4.5" OD x 75" effective length
- 500,000 Btu/hr total required heat release - recuperated
- 1650° F chamber temperature
- open radiant angles (not enclosed tubes).

1. The required heat release per tube:

$$\frac{\text{total required heat release}}{\text{number of tubes}} = \text{Required heat release per tube}$$

- $500,000/4 = 125,000$ Btu/hr

2. Tube surface area for each tube:

$$OD \times \pi \times n \times L = \text{Tube surface area}$$

- $4.5 \times 3.142 \times 2 \times 75 = 2120.85$ in².

(n=2 Because it is a U-tube which has two legs).

3. From Table 3.1 "Maximum heat transfer rate" on page 10, find the maximum heat transfer rate:

- 60 Btu/in²/hr.

4. The maximum permissible heat release (per tube) is:

$$\text{tube surface area} \times \text{max heat transfer rate} = \text{Maximum heat release}$$

$$- 2120.85 \times 60 = 127,251 \text{ Btu/hr .}$$

5. This is sufficient, because only 125,000 Btu/hr is required.

6. From Table 4.2 "Efficiency" on page 11, find the efficiency with a recuperator at 1650°F:

$$- 64\%.$$

7. The gross burner input (per tube) is:

$$\frac{\text{Required heat release}}{\text{Efficiency}} \times 100 = \text{Gross burner input}$$

$$- (125,000 / 64) \times 100 = 195,312 \text{ Btu/hr.}$$

Size the system for 200,000 Btu/hr per burner.

8. Compare the result from step 7 to the required maximum inputs in Table 4.3 on page 12. Gross input is less than 300,000 Btu/hr, therefore, the 4" I.D. tube can be used.

Air tube length

The air tube length varies based on the location of the hot face of the furnace relative to the mounting flange of the burner.

Figure 3.1 Air tube length

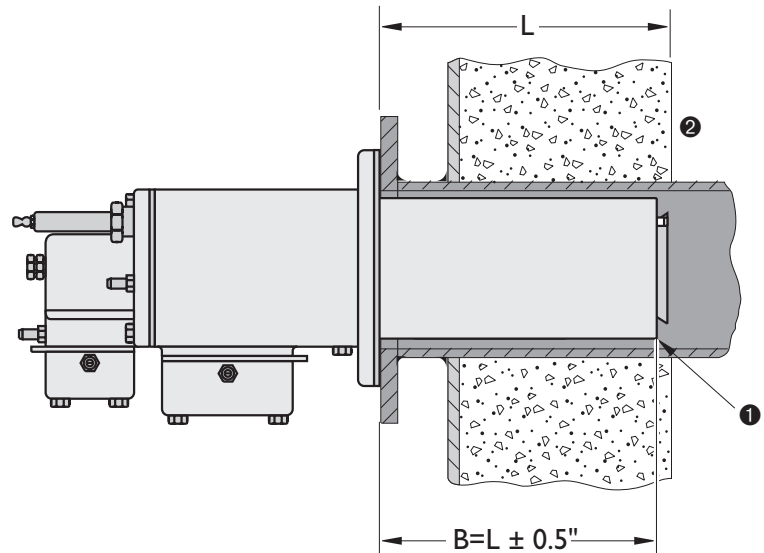

The end of the air tube ① must be within ± 0.5 " of the face of the furnace wall ②.

You must choose the length closest to your requirements. You can find the air tube lengths (dimension B) that are available in the appropriate Data Sheet. 310-1 (30 TFB), 310-2 (75TFB), 310-3 (200TFB).

Step 1b: Immersion tube burner application

Determine the net heat release required to the tank

The net heat release to the tank is derived from heat balance calculations. These calculations are based on the heat-up and steady-state requirements of the process, and take into account surface losses, tank wall losses and tank heat storage. Detailed guidelines for heat balance calculations are in the Eclipse Combustion Engineering Guide (EFE 825).

Determine the efficiency

The efficiency of the tube is directly linked to the effective tube length. The diameter of the tube has no influence on the efficiency. The efficiency of the tube is the factor between the burner input to the tube and net output to the tank. At a given burner input, the net output to the tank is higher for a longer tube than for a relatively short tube.



Note:

A commonly used efficiency is 70%. Efficiencies greater than 85% will produce condensation in the tube which may shorten tube life or disrupt the system.

Figure 3.2 below shows the relationship between the tube length and the efficiency.

Figure 3.2 Effective tube length

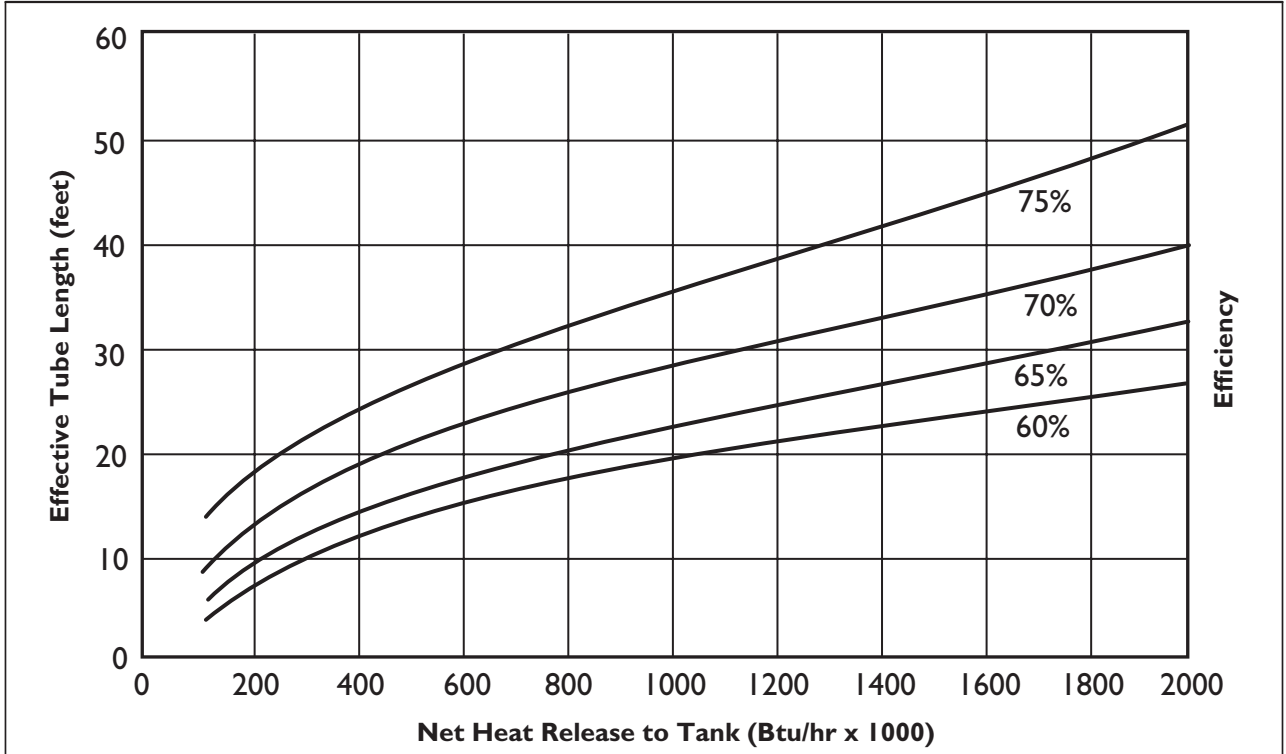

The effective tube length required is a function of the efficiency chosen.

The effective length of a tube is the total length of straight tube covered by liquid. Add 1/3" for each 90° bend.

Calculate the gross burner input

Calculate the gross burner input in (Btu/hr) with this formula:

$$\text{Gross Burner input} = \frac{\text{Net heat release to the tank}}{\text{Tube efficiency}}$$

Compare the gross burner input

Compare the gross burner input with the maximum tube input. If the gross burner input is greater than the maximum tube input from the table below, then the size of the immersion tube must be increased.

Table 3.4 Maximum tube input

TUBE I.D. (INCHES)	MAXIMUM INPUT (1000's BTU/HR)
4	300
5	600
6	900
8	1500
10	2500
12	3500

Exceeding these inputs may result in burner pulsation or other operational problems.

Sizing example

Application parameters

- Net heat release required to tank: 1,000,000 Btu/hr
- Efficiency: 70%
- Effective tube length: (Fig. 3.2) 37'
- Gross Burner Input: $1,000,000 / .70 = 1,428,571$ Btu/hr
- 200TFB Burner: 2,000,000 Btu/hr maximum capacity
- Minimum Tube I.D. : (Table 3.4) = 8"
- Tube Surface Area/sq. in. = $O.D. \times \pi \times L$
 - $O.D. = 8.625$
 - $\pi = 3.142$
 - $L = \text{Total effective tube length in inches} = (37 \times 12) = 444"$
 - $8.625 \times 3.142 \times 444 = 12,032.3$ sq. in.
- $\text{Btu/hr/sq.in} = \text{Net heat release to tank} / \text{sq.in. surface area}$
 $1,000,000 / 12,032.3 = 83.1$ Btu/sq.in./hr



Note:

If the medium to be heated in the above example was cooking oil, it would be necessary to increase tube length or select a larger tube. It is recommended that you not exceed 50 Btu/hr/sq.in. for cooking oil.

Air tube length

The air tube length should be as short as possible to maximize the exposure of the immersion tube to the flame.



Caution:

Any section of immersion tube that extends beyond the nozzle, must be submerged in the liquid. Dimension B must be greater than Dimension A.

Figure 3.3 Air tube length

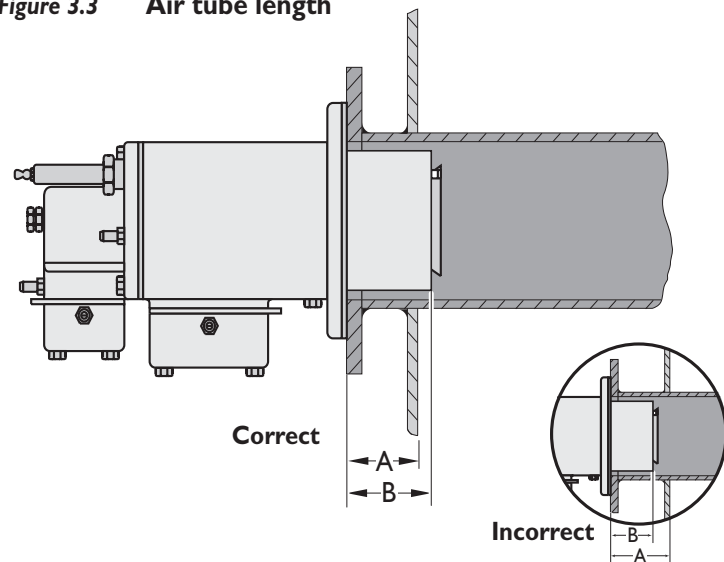

Choose the shortest tube length (Dimension B) that is greater than Dimension A. You can find the air tube lengths (dim. B) that are available in the appropriate Data Sheet. 310-1 (30TFB), 310-2 (75TFB), 310-3 (200TFB).

Tube design

1. Elbows

- a. We recommend the use of standard and sweep elbows only.
- b. The first elbow should be at least eight tube diameters from the face of the burner.

2. Stack

- a. Make sure that the stack is large enough to handle the exhaust flow plus the dilution air.
- b. The stack must be at least one pipe size larger than the tube exhaust.



Note:

Detailed guidelines for flue sizing calculations are in the *Eclipse Combustion Engineering Guide (EFE 825)*.

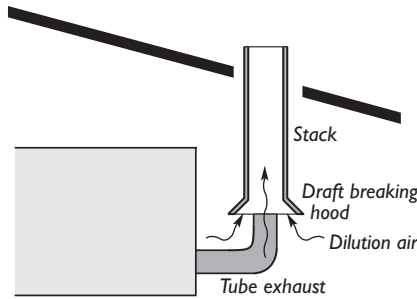

Step 2: Control methodology

3. Draft breaking hood

A draft breaking hood is an open connection between the heater tube exhaust and the exhaust stack. It allows fresh dilution air to pass into the exhaust and mix with the exhaust gases.

The advantages of a draft hood are:

- the burner operation is less sensitive to atmospheric conditions
- the temperature of the exhaust gases is lower when they pass through the roof.



Note:

Make sure that it is possible to get access between the draft hood and the tube exhaust. Then you can install a damper plate if acoustic feedback occurs in the tube.

The control methodology is the basis for the rest of the design process. Once you know what your system will look like, you can select the individual components. Which control methodology you choose depends on the type of process that you want to control.

Control methods

There are two main methods to control the input of a ThermThief system:

1. Modulating control

A burner system with modulating control gives an input that is in proportion with the demands of the process. Any input between high and low fire is possible. The burner operates at 15% excess air at high fire, and 100% excess air (min.) at low fire.

2. High/low control

A system with high/low control gives a high or low fire input to the process. No input between high and low fire is possible. The burner operates at 15% excess air at high fire, and 100% excess air (min.) at low fire.

The only difference in the components is the type of actuator on the automatic butterfly valve (control valve ❶, page 19).

On the next page you will find schematics of these control methods. The symbols in the schematics are explained in the Appendix on page 28.

Automatic gas shut-off by burner (optional)

As an option, an automatic gas shut-off valve can be installed.

If the flame monitoring system detects a failure, the gas shut-off valve closes, interrupting the gas supply to the burner that caused the failure.

System schematics

1. Air
The control valve ① is in the air line. It sets the air flow to the required value.
2. Gas
The ratio regulator ② allows the required amount of gas to go to the burner. Low fire gas is limited by ratio regulator ②. High fire gas is limited by the manual butterfly valve ③.

Figure 3.4 System schematics (Modulating or High/Low control)

Combustion air at ambient temperature (Radiant & Immersion applications)

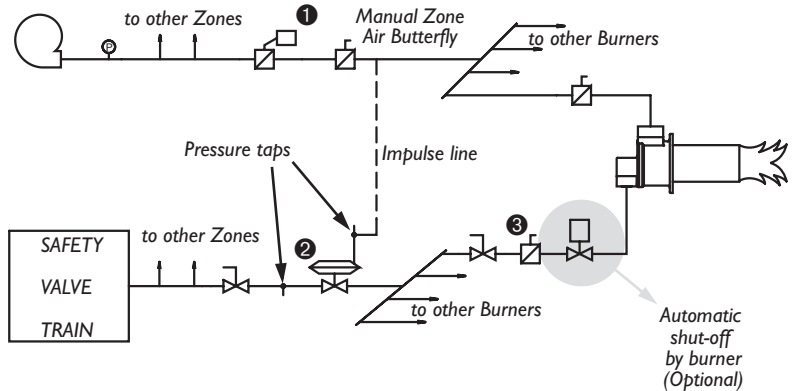

Pre-heated combustion air (Radiant applications)

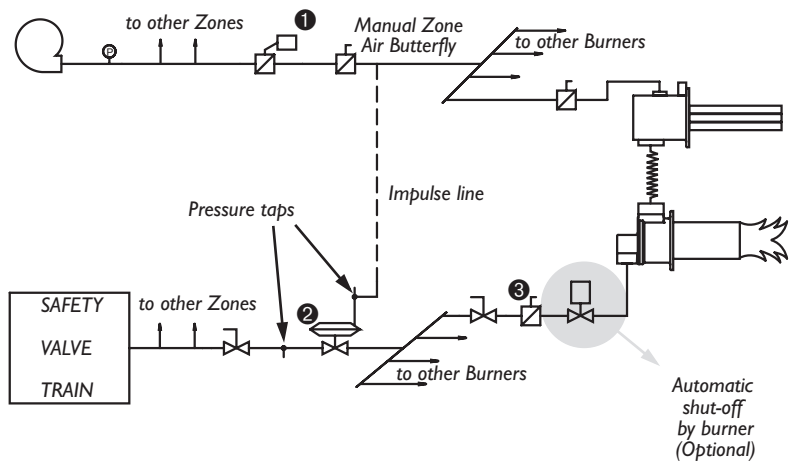

Step 3: Ignition System

For the ignition system use:

- 6000 VAC transformers
- full wave spark transformers
- one transformer per burner.

Do NOT use:

- 10,000 VAC transformers
- twin outlet transformers
- distributor type transformers
- half wave spark transformers.

ThermThief burners are capable of direct spark ignition anywhere within the listed operating range. However, it is recommended that low fire start be used. Local safety and insurance requirements demand that you limit the maximum time that a burner takes to ignite. These time limits vary from country to country. For the USA the time limit is 15 seconds, for Europe it is 3 seconds.

The time that a burner takes to ignite depends on:

- the distance between the gas shut-off valve and the burner
- the air/gas ratio
- the gas flow at start conditions.

In the USA, with a time of 15 seconds to ignition, there should be sufficient time to ignite the burners. It is possible, however, to have the low fire too low to ignite within the time limit. Under these circumstances you must consider the following options:

- start at higher input levels
- resize and/or relocate the gas controls

Step 4: Flame monitoring system

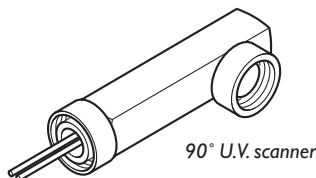
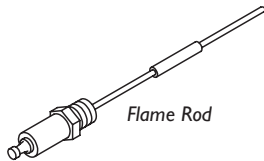

A flame monitoring system consists of two main parts:

- a flame sensor
- flame monitoring control.



Note:

A flame monitoring system may not be required. Check your local standards to verify.

Flame sensor

Flame sensing is by flame rod (TFB030 & TFB075) or U.V. scanner (all models). Eclipse recommends the following U.V. scanners for use with the Eclipse flame monitoring controls listed on page 21:

- straight UV scanner; Bulletin / Info Guide 854
- 90° UV scanner; Bulletin / Info Guide 852
- self-check UV scanner; Bulletin / Info Guide 856
- solid state UV/IR scanner; Bulletin / Info Guide 855.



Note:

When using a U.V. scanner, using mounting adaptor part #. 10033 will ensure that the U.V. scanner does not detect the ignition spark.

Step 5: Combustion Air System: Blower and air pressure switch

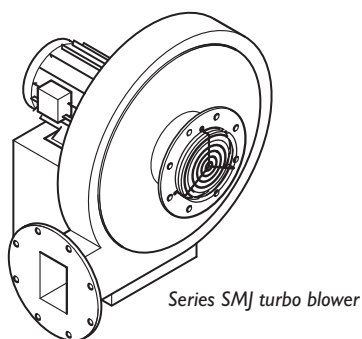

Flame monitoring control

The flame monitoring control is the equipment that processes the signal from the U.V. scanner or flame rod.

For flame monitoring control selection there are several options:

- flame monitoring control for each burner: if one burner goes down, only that burner will be shut-off.
- multiple burner flame monitoring control: if one burner goes down, all burners will be shut-off.

There are three flame monitoring controls that are recommended:

- Bi-flame series; see Bulletin/Info guide 826
- Multi-flame series 6000; see Bulletin/Info guide 820
- Veri-flame; see Bulletin/Info guide 818.

Other manufacturer's flame monitoring systems can be used with the burner if spark is maintained for a fixed time interval and is not interrupted when a flame signal is detected during trial for ignition.

The effects of atmospheric conditions

Blower data is based on the International Standard Atmosphere (ISA) at Mean Sea Level (MSL), which means that it is valid for:

- sea level
- 29.92" Hg
- 70°F.

If you are above sea level or in a hot area, the properties of the air are different. As the density of the air decreases, the outlet pressure and the flow of the blower decreases.

An accurate description of these effects is in the Eclipse Combustion Engineering Guide (EFE 825). The Guide contains tables for the effect of pressure, altitude and temperature on air.

Blower

The rating of the blower must match the system requirements. You can find all the blower data in:

- Bulletin / Info Guide 610.

Follow these steps:

1. Calculate the outlet pressure.

When you calculate the outlet pressure of the blower, you must calculate the total of these pressures:

- the static air pressure required at the burner
- the total pressure drops in the piping
- the total of the pressure drops across the valves
- the pressure in the radiant or immersion tube (suction or pressurized)
- recommend safety margin of 10%.

Step 5: Combustion Air System: Blower and air pressure switch (continued)

2. Calculate the required flow

The blower output is the air flow delivered under standard atmospheric conditions. It must be enough to feed all the burners in the system at high fire.

Combustion air blowers are normally rated in terms of standard cubic feet per hour (scfh) of air.

An example calculation follows the information tables below:

Table 3.5 Required calculation information

DESCRIPTION	UNIT OF MEASURE	FORMULA SYMBOL
Total system heat input	Btu/hr	Q
Number of burners	-	-
Type of fuel	-	-
Gross heating value of fuel	Btu/ft ³	q
Desired excess air percentage (Typical excess air percentage @ high fire is 15%)	percent	%
Air/Gas ratio (Fuel specific, see table below)	-	
Air flow	scfh	V _{air}
Gas flow	scfh	V _{gas}

Table 3.6 Fuel gas heating values

FUEL GAS	STOICHIOMETRIC* AIR/GAS RATIO α (ft ³ _{air} / ft ³ _{gas})	GROSS HEATING VALUE q (Btu/ft ³)
Natural gas (Birmingham, AL)	9.41	1,002
Propane	23.82	2,572
Butane	30.47	3,225

* Stoichiometric: No excess air. The precise amount of air and gas are present for complete combustion.

EXAMPLE BLOWER CALCULATION

Application example:

"A batch furnace has been designed and requires a heat input of 2,900,000 btu/hr. It has been decided to provide the required heat input with four burners operating on natural gas using 15% excess air."

Calculation example:

- a. Decide which ThermThief burner model is appropriate:

$$\frac{Q \text{ (total heat input) of } 2,900,000 \text{ btu/hr}}{4 \text{ burners}} = 725,000 \text{ Btu/hr/burner}$$

- Select 4 Model TFB075 ThermThief burners based on the required heat input of 725,000 Btu/hr for each burner.

- b. Calculate required gas flow:

$$V_{\text{gas}} = \frac{Q}{q} = \frac{2,900,000 \text{ btu/hr}}{1,002 \text{ Btu/ft}^3} = 2,894 \text{ ft}^3/\text{hr}$$

- Gas flow of 2,894 ft³/hr is required

- c. Calculate required stoichiometric air flow:

$$\begin{aligned} V_{\text{air-Stoichiometric}} &= (\alpha \text{ air/gas ratio}) \times V_{\text{gas}} = 9.41 \times 2,894 \text{ ft}^3/\text{hr} \\ &= 27,235 \text{ ft}^3/\text{hr} \end{aligned}$$

- Stoichiometric air flow of 27,235 scfh required

- d. Calculate final blower air flow requirement based on the desired amount of excess air:

$$\begin{aligned} V_{\text{air}} &= (1 + \text{excess air \%}) \times V_{\text{air-Stoichiometric}} \\ &= (1 + 0.15) \times 27,235 \text{ ft}^3/\text{hr} = 31,320 \text{ ft}^3/\text{hr} \end{aligned}$$

- For this example, final blower air flow requirement is 31,320 scfh at 15% excess air.



Note:

It is common practice to add an additional 10% to the final blower air flow requirement as a safety margin.

3. Find the blower model number and motor horsepower (hp).

With the output pressure and the specific flow, you can find the blower catalog number and the motor hp in Bulletin / Info Guide 610.

4. Eclipse Combustion recommends that you select a Totally Enclosed Fan Cooled (TEFC) motor.

5. Select the other parameters:

- inlet filter or inlet grille
- inlet size (frame size)
- voltage, number of phases, frequency
- blower outlet location, and rotation direction Clockwise (CW) or Counter Clockwise (CCW).

Step 5: Combustion Air System: Blower and air pressure switch (continued)

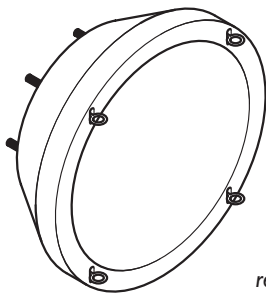

Inlet filter with replaceable filter element

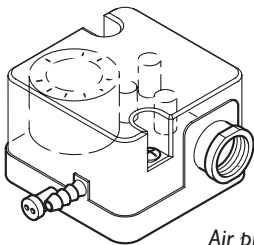

Air pressure switch

Step 6: Main gas shut-off valve train



Main gas shut-off valve train



Step 7: Process Temperature Control System



Note:

The use of an inlet air filter is strongly recommended. The system will perform longer and the settings will be more stable.



Note:

When selecting a 60 Hz Blower for use on 50 Hz, a pressure and capacity calculation is required. See Eclipse Combustion Engineering Guide (EFE 825)

The total selection information you should now have:

- blower model number
- motor hp
- motor enclosure (TEFC)
- voltage, number of phases, frequency
- rotation direction (CW or CCW).

Air pressure switch

The air pressure switch gives a signal to the monitoring system when there is not enough air pressure from the blower.

You can find more information on pressure switches in:

- Blower Bulletin 610



Warning:

Eclipse Combustion supports NFPA regulations, which require the use of an air pressure switch in conjunction with other safety components, as a minimum standard for main gas safety shut-off systems.

Consult Eclipse

Eclipse can help you design and obtain a main gas shut-off valve train that complies with the current safety standards.

The shut-off valve train must comply with all the local safety standards set by the authorities that have jurisdiction.

For details, please contact your local Eclipse Combustion representative or Eclipse Combustion.



Note

Eclipse Combustion supports NFPA regulations (two shut-off valves) as a minimum standard for main gas safety shut-off systems.

Consult Eclipse

The process temperature control system is used to control and monitor the temperature of the system. There is a wide variety of control and measuring equipment available.

For details, please contact your local Eclipse Combustion representative or Eclipse Combustion.



Appendix

CONVERSION FACTORS

Metric to English

This table also contains a few Metric to Metric conversions.

FROM	TO	MULTIPLY BY
kg	lb	2.205
kPa	mbar	10
kW	Btu/hr	3414
m	ft	3.28
m ³	ft ³	35.31
m ³ /h	cfh	35.31
mbar	In wc	0.401
mbar	kPa	0.1
mbar	Psi	14.5 × 10 ⁻³
mm	In	3.94 × 10 ⁻²
°F = 9/5 °C + 32		









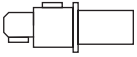
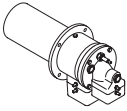
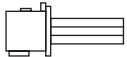
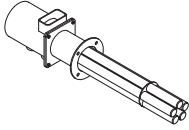

English to Metric



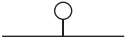

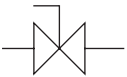
This table also contains a few English to English conversions.

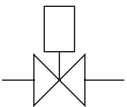
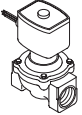
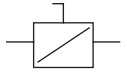
FROM	TO	MULTIPLY BY
Btu/hr	kW	0.293 × 10 ⁻³
cfh	m ³ /h	2.832 × 10 ⁻²
ft	m	0.3048
ft	In	12
ft ³	m ³	2.832 × 10 ⁻²
In	ft	8.333 × 10 ⁻²
In	mm	25.4
In wc	mbar	2.49
lb	kg	0.454
Psi	mbar	68.95
°C = 5/9 (°F - 32)		

KEY TO THE SYSTEM SCHEMATICS

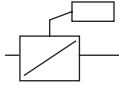
Symbols used in the schematics on page 19.

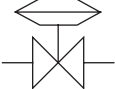
SYMBOL	APPEARANCE	NAME	REMARKS	BULLETIN/ INFO GUIDE
		ThermThief burner	Available sizes: <ul style="list-style-type: none"> • 30 TFB • 75 TFB • 200 TFB. 	
		Recuperator	A recuperator is a heat exchanger. It transfers heat from the exhaust gases to the combustion air. Doing that can improve the thermal efficiency of the burner by as much as 20%.	318
		Safety valve train	Eclipse Combustion strongly endorses NFPA as a minimum.	756
		Combustion air blower	The combustion air blower provides the combustion air to the burner(s).	610
		Air pressure switch	The air pressure switch gives a signal to the safety system when there is not enough air pressure from the blower.	610
		Gas cock	Gas cocks are used to manually shut off the gas supply on both sides of the main gas shut-off valve train.	710
		Solenoid valve	Solenoid valves are used to automatically shut off the gas supply on small capacity burner systems.	760
		Manual butterfly valve	Manual butterfly valves are used to balance the air flow at each burner, and/or to control the zone flow.	720

SYMBOL	APPEARANCE	NAME	REMARKS	BULLETIN/ INFO GUIDE
		Automatic butterfly valve	Automatic butterfly valves are typically used to set the output of the system.	720
		Ratio regulator	A ratio regulator is used to control the air/gas ratio. The ratio regulator is a sealed unit that adjusts the gas flow in ratio with the air flow. To do this, it measures the air pressure with a pressure sensing line, the impulse line. This impulse line is connected between the ratio regulator and the air supply line.	742



Offered By:

Power Equipment Company
2011 Williamsburg Road
Richmond, Virginia 23231
Phone (804) 236-3800
Fax (804) 236-3882

www.peconet.com